

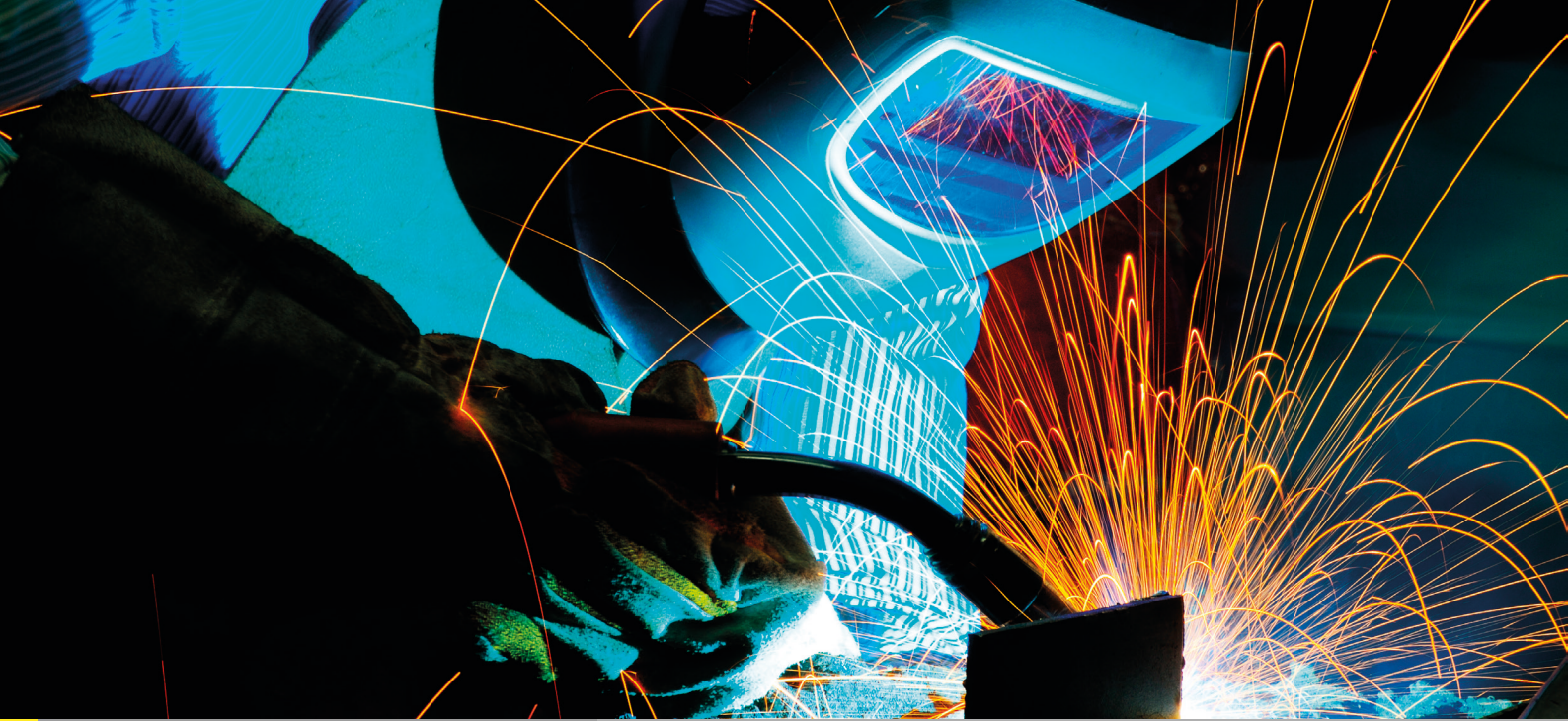

MDB-2 HIGH VACUUM

On torch extraction capture
and filtration



DO YOU CONTROL DUST AND FUMES?

We do. Controlling fumes and dust in a production plant significantly contributes to a better work environment. Background concentrations of dust and fumes must be kept as low as possible. This can be achieved by using the right processes and using quality fume and dust extraction and filtration, this prevents accumulation of fumes in your working environment.

As a specialist in air cleaning technology and expert in filtering fumes from metal-working industry, Plymovent offers various solutions to control fumes and dust, like source extraction, extraction hoods and general ventilation and filtration systems.

THE MDB-2/HIGH VACUUM UNIT WITH EXCELLENT PERFORMANCE AND WITH LOW NOISE LEVELS.

On torch extraction is an efficient way to capture welding fumes at source. The MDB-2/HV is a highly effective self-cleaning welding fume extraction system with an integrated high vacuum (HV) fan for the connection up to 10 fume extraction torches running at the same time. This system is perfect even for heavy, manual welding processes and long welding runs. The high vacuum, high efficiency fan is placed in an air cooled, sound-absorbing box with, as standard, a duct silencer resulting in a low sound level. Flexibility is key to the MDB-2/HV with inlets on both sides of the unit.

HEAVY DUTY

This unit combines a rigid design, over-sized filter cartridges, and a powerful blower, making it ideal for heavy industrial use with heavy welding.

LOW SOUND LEVEL

A powerful 14,5 kW fan in an air cooled sound-absorbing box and an additional duct silencer on the outlet ensures a sound level of only 68 dB(A).

EXHAUST FAN CURVE

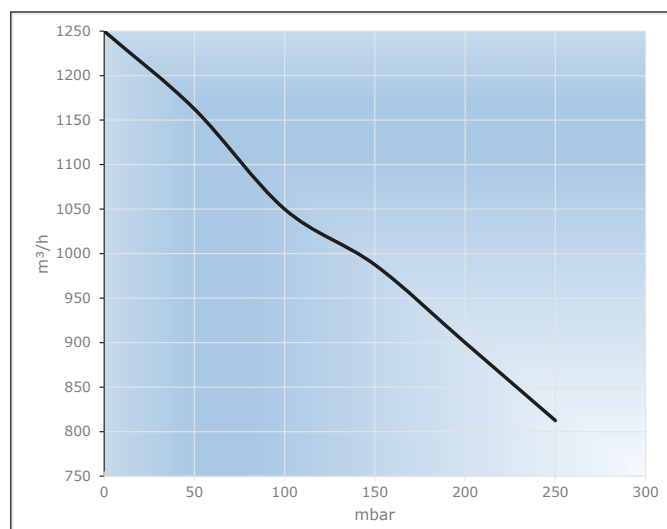

FEATURES

Low sound level

A powerful 14,5 kW fan in an air cooled sound-absorbing box and an additional duct silencer on the outlet enhances a sound level to only 68 dB(A).

Automatic filter cleaning

A RamAir™ pulse amplifier is placed in each filter cartridge and disperses the pulse energy directly to the filter medium making for efficient cleaning and long filter life.

Large dustbin

The 80 litres dustbin with handle and connection lift ensures no leakage and easy emptying.

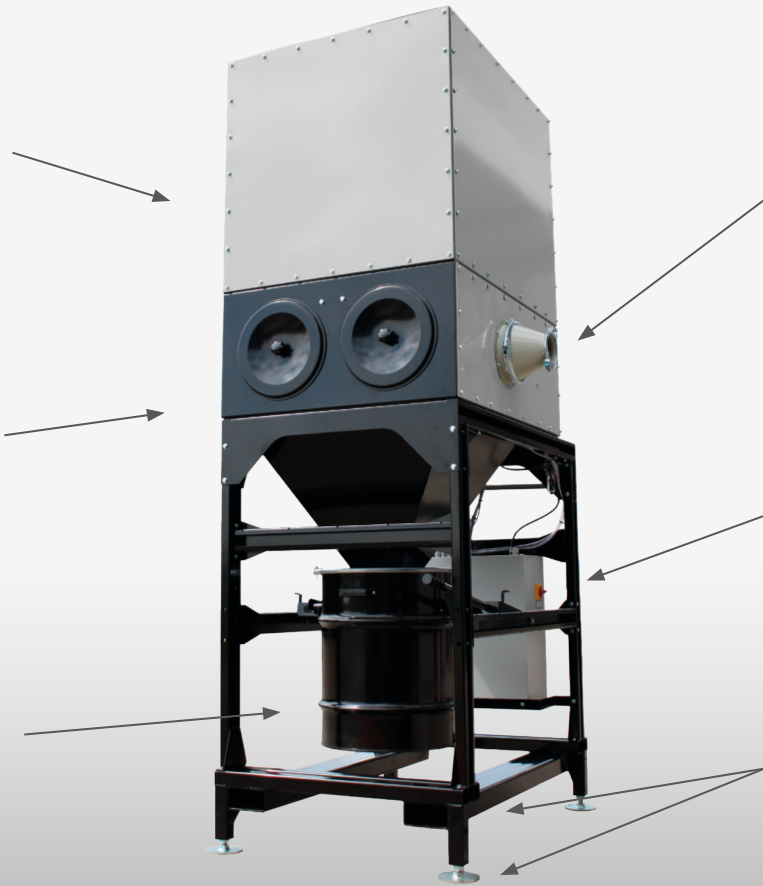

Controlled fan speed

A Variable Frequency Controller can seamlessly adapt the fan speed from 20 to 60Hz.

Left and right connection

Simple connection with quick connect coupling.

ControlPro

A filter control system designed with the user in mind to control your extraction system automatically:

- Intelligent filter cleaning
- Connection for external devices
- Software updates
- 7" touch display
- Data logging
- Auto start/stop by weekly timer
- Network connection

Easy to move

Forklift holders and adjustable feet to re site the unit.

SYSTEM OVERVIEW

The MDB-2/HV has a standard spark arrester (SparkTrap). The captured welding fume passes through this spark arrester to protect the filter cartridges inside the unit against sparks.*The two CART-PTFE/10 filter cartridges filter the polluted air with a very high efficiency. The large surface area and structure of the filter cartridges ensure efficiency, low maintenance and prolonged filter life. The filtered air is returned into the workshop by the outlet on top of the fan. Because the fan is in an air cooled sound-absorbing box and the MDB-2/HV has as standard a duct silencer the sound level is extremely low.

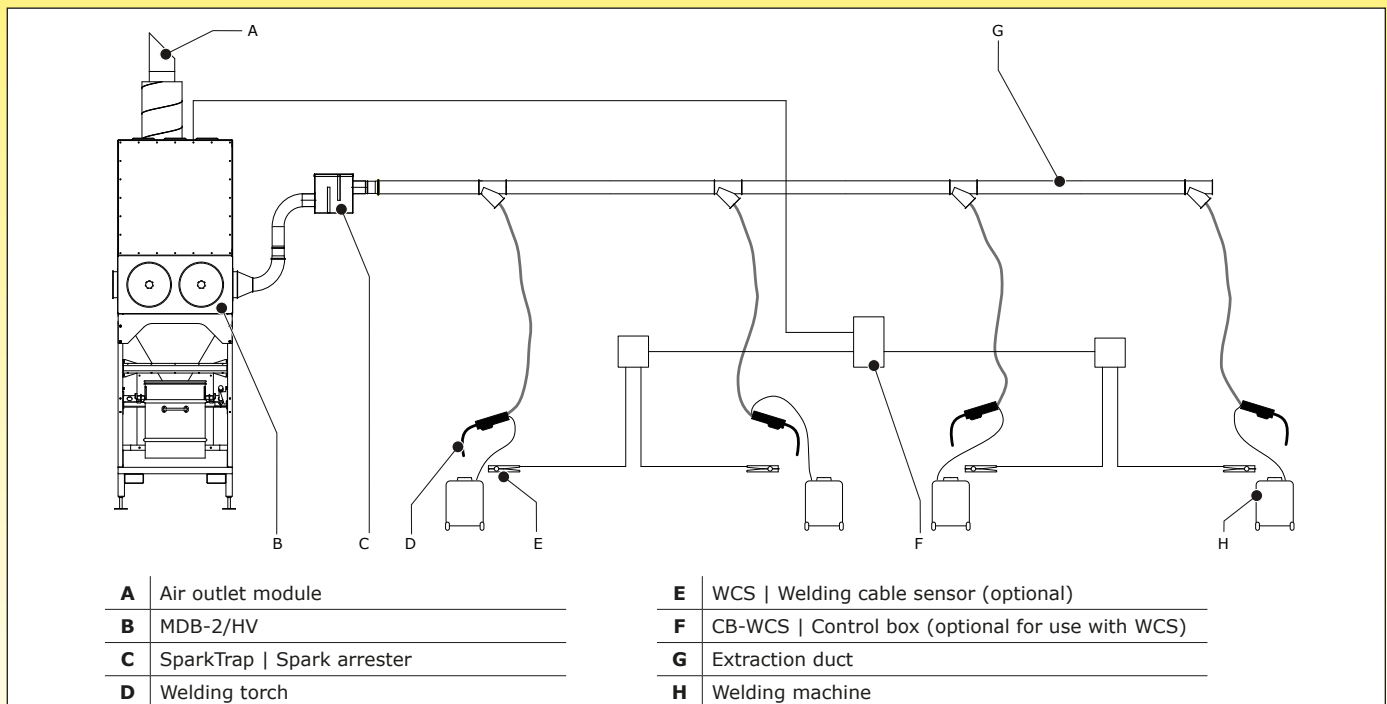

*Optional; FlameShield, which is a built-in fire extinguishing generator that is activated by a manual call point and/or by a temperature switch when the temperature rises above 70°C

TECHNICAL SPECIFICATIONS

Filter surface	20 m ²	Spark arrester	Standard with labyrinth SparkTrap
Filter material	BiCo spunbond polyester with PTFE membrane	Fan	14,5 kW High Vacuum Blower with pressure relief valve
Welding fume class	W3 according to ISO 15012-1:2013	Noise level	68 dB(A)
Extraction capacity	1000 m ³ /h @ 15000 Pa 850 m ³ /h @ 25000 Pa	Capacity dustbin	80 litres
Fan control	VFD-HV panel with Variable Frequency Inverter fan speed manual adjustable from 20 to 60Hz	Weight	400 kg
Connection voltage	380V/3ph/50Hz 480V/3ph/60Hz 600V/3ph/60Hz	Filter control	ControlPro with touchscreen HMI and internet connection
Fire Suppression system	Optional		

DIMENSIONS

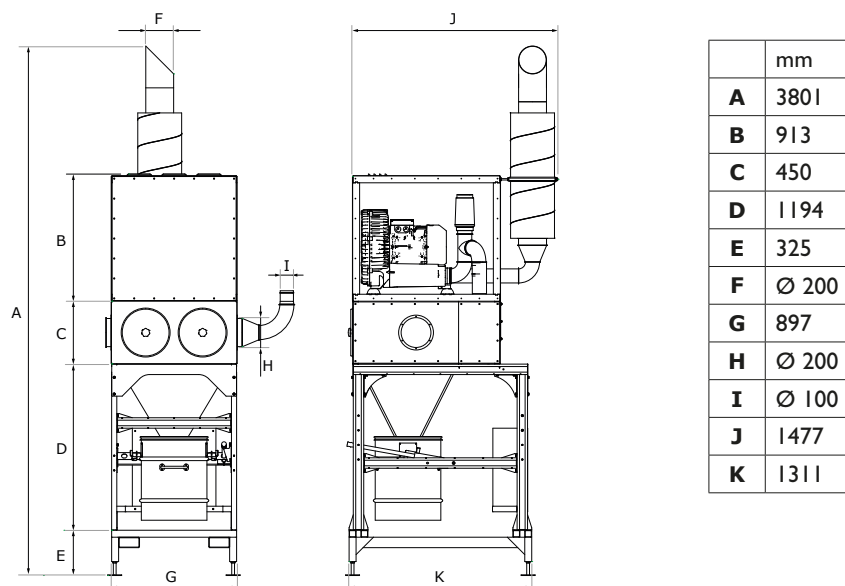

PLYMOVENT[®]
clean air at work

International Distributor
Sales
Plymovent Group BV
P.O. Box 9350
1800 GJ Alkmaar
The Netherlands

T +31 (0)72 5640 604
F +31 (0)72 5644 469
E export@plymovent.com

PLYMOVENT OFFERS TOTAL SOLUTIONS FOR AIR CLEANING

For over 45 years, Plymovent has been gaining experience in the field of air cleaning. We not only have extensive knowledge of the extraction and filtration of welding fumes and oil mist in metalworking industries, we are also specialised in the removal of vehicle exhaust fumes.

Your authorised Plymovent distributor:

Plymovent cares about the air you breathe. We offer products, systems and services which ensure clean air at work, anywhere in the world.

We respect the environment and we deliver high-quality products. Our expertise gained over many years and our genuine commitment to customer requirements enable us to provide precisely the solutions you need.

Plymovent reserves the right to make design changes.

www.plymovent.com